

PLATES AND BUSHES

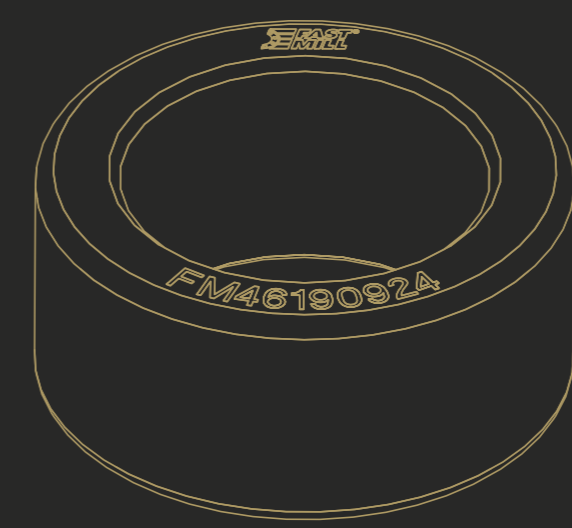

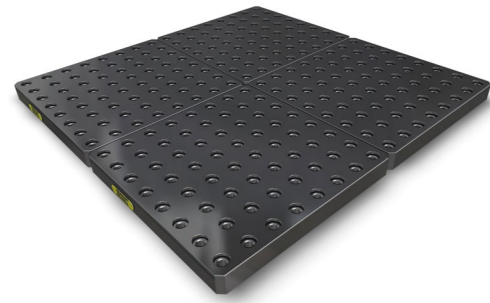

FINISHED MODULAR PLATE

Modular plate, is the first step in equipping a machine with FastMill technology, it allows the user to obtain a grid drilled plate in tolerance directly on the machine table. Made with the utmost precision, it ensures known points where to fix the FastMill systems.

AVAILABLE WITH:

- fixing hole
- pin reference
- centrale hole
- alphanumeric marking
- special size

AVAILABLE ON STOCK

CODE	DESCRIPTION	L x C	H	GRID	Ø	M
FM46195202	Finished modular plate	500X500 (19,6"X19,6")	40 (1,57")	50 (1,96")	24H	16
FM46195210	Finished modular plate	800X800 (31,4"X31,4")	40 (1,57")	50 (1,96")	24H	16
FM46195205	Finished modular plate	1000X500 (39,3"X19,6")	40 (1,57")	50 (1,96")	24H	16
FM46195206	Finished modular plate	1000X600 (39,3"X23,6")	40 (1,57")	50 (1,96")	24H	16
FM46195207	Finished modular plate	1000X800 (39,3"X31,4")	40 (1,57")	50 (1,96")	24H	16
FM46195208	Finished modular plate	1000X1000 (39,3"X39,3")	40 (1,57")	50 (1,96")	24H	16

ON DEMAND

CODE	DESCRIPTION	L x C	H	GRID	Ø	M
FM_PLATE	Finished modular plate	STEP 100X100	40 (1,57")	50 (1,96")	24H / ...	16 / ...
FM_PLATE	Finished modular plate	STEP 100X100	40 (1,57")	100 (3,94")	24H / ...	16 / ...

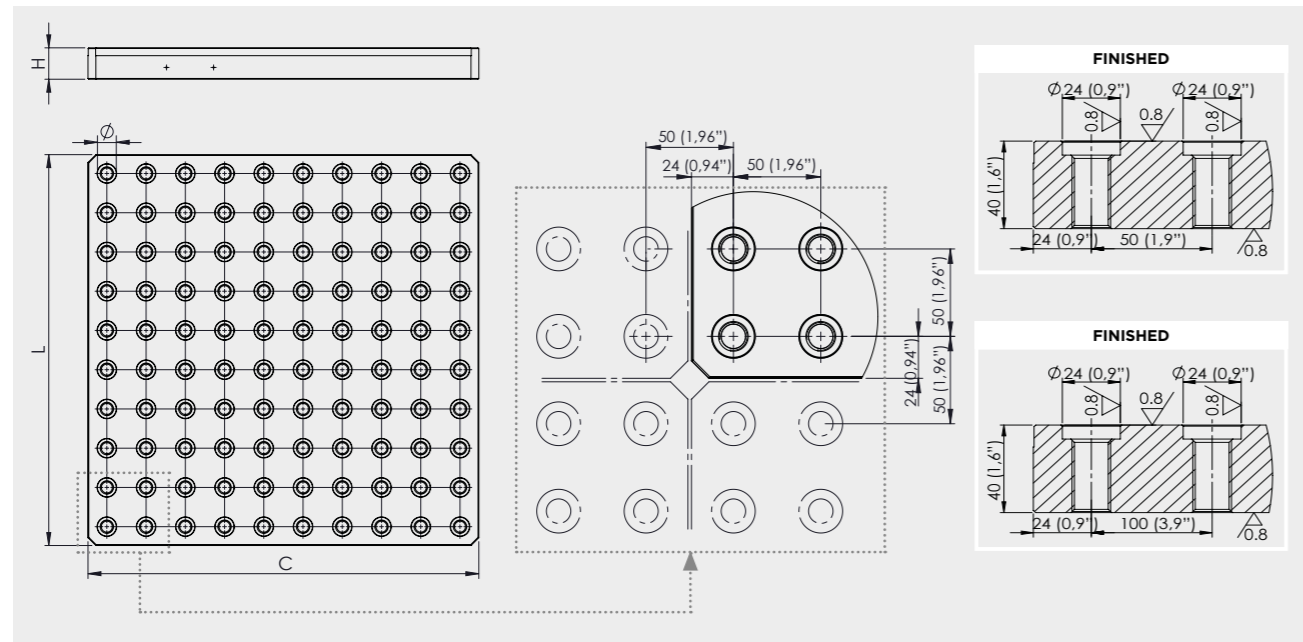

CAP FOR PLATE

Threaded plug to cover the plate holes when not in use. They prevent chips and dirt from entering the tolerance counterbore.

CODE	DESCRIPTION	Ø	M
FM46191016	Cap for plate	24 (0,94")	M16
FM46191012	Cap for plate	20 (0,78")	M12
FM46191011	Cap for plate	18 (0,70")	M12

FINISHED MODULAR PLATE EXAMPLE ON DEMAND

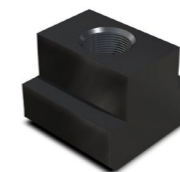
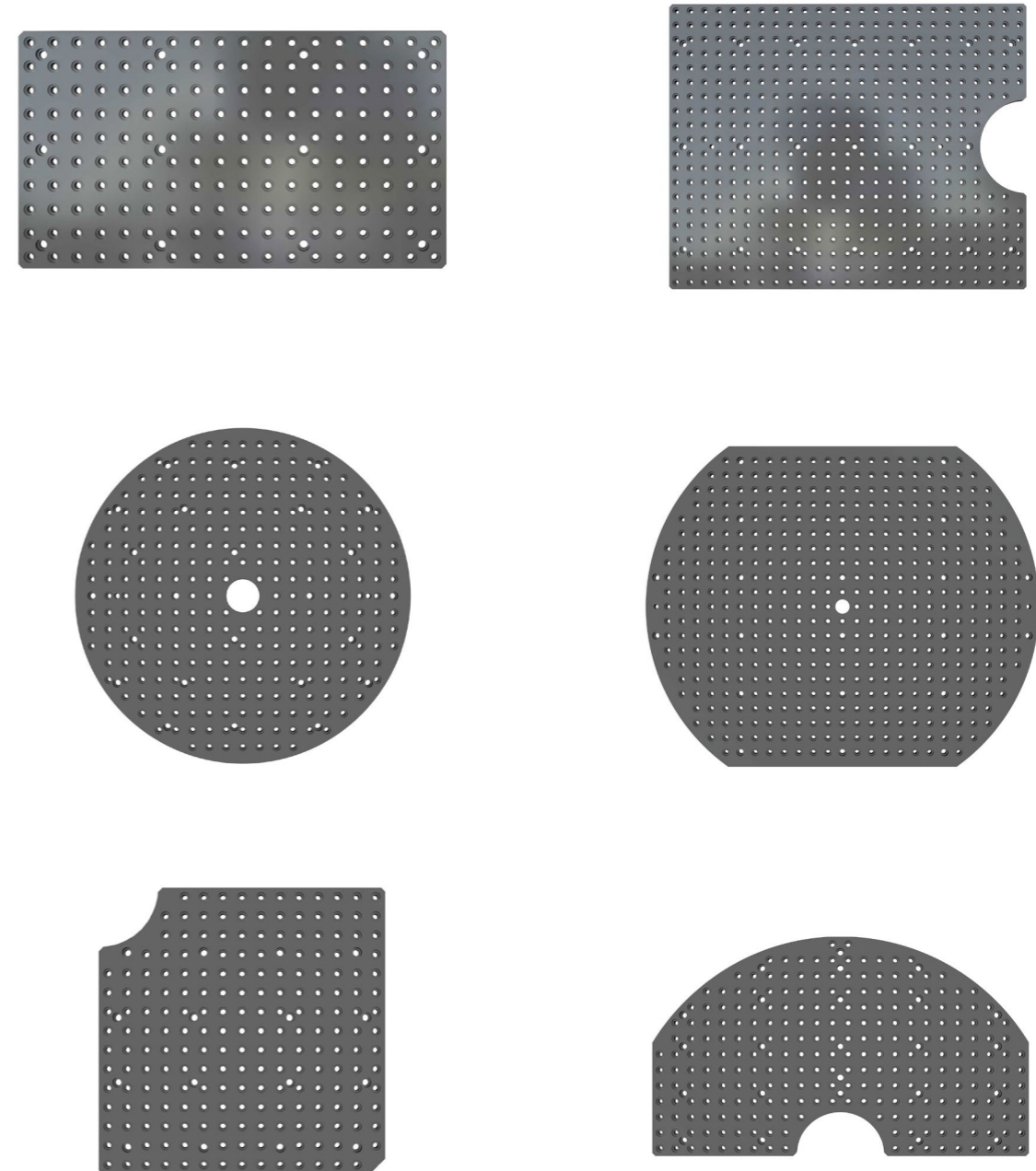

T-NUT

CODE	DESCRIPTION	T	M	CODE	DESCRIPTION	T	M
FM36008012	T-Nut	T12	M8	FM36016022	T-Nut	T22	M16
FM36008014	T-Nut	T14	M8	FM36016024	T-Nut	T24	M16
FM36012014	T-Nut	T14	M12	FM36016028	T-Nut	T28	M16
FM36012018	T-Nut	T18	M12	FM36316028 *	T-Nut	T28	M16
FM36016018	T-Nut	T18	M16				

* Rhomboidal version.

PLATES AND BUSHES
MODULES AND PINS D90
MODULES AND PINS D49
SPACERS
RISERS
THIRD POINT
MAGNETIC
VERTICAL CLAMPING
MINI RANGE
FASTMILL ZERO
CLAMPS

PLATES AND BUSHES
MODULES AND PINS D90
MODULES AND PINS D49
SPACERS
RISERS
THIRD POINT
MAGNETIC
VERTICAL CLAMPING
MINI RANGE
FASTMILL ZERO
CLAMPS

PATENTED



TRILOB

The innovative patented Trilob bush, designed to adapt to varying geometric tolerances, provides reliable centering in any situation. This ensures maximum rigidity and stability during machining, enhancing precision and performance in all your projects.

CODE	DESCRIPTION	HEIGHT	Ø	WEIGHT
FM46190900	Trilob bush	11 (0,43")	20 - 24 (0,78" - 0,94")	0,01 Kg (0,02 lbs)

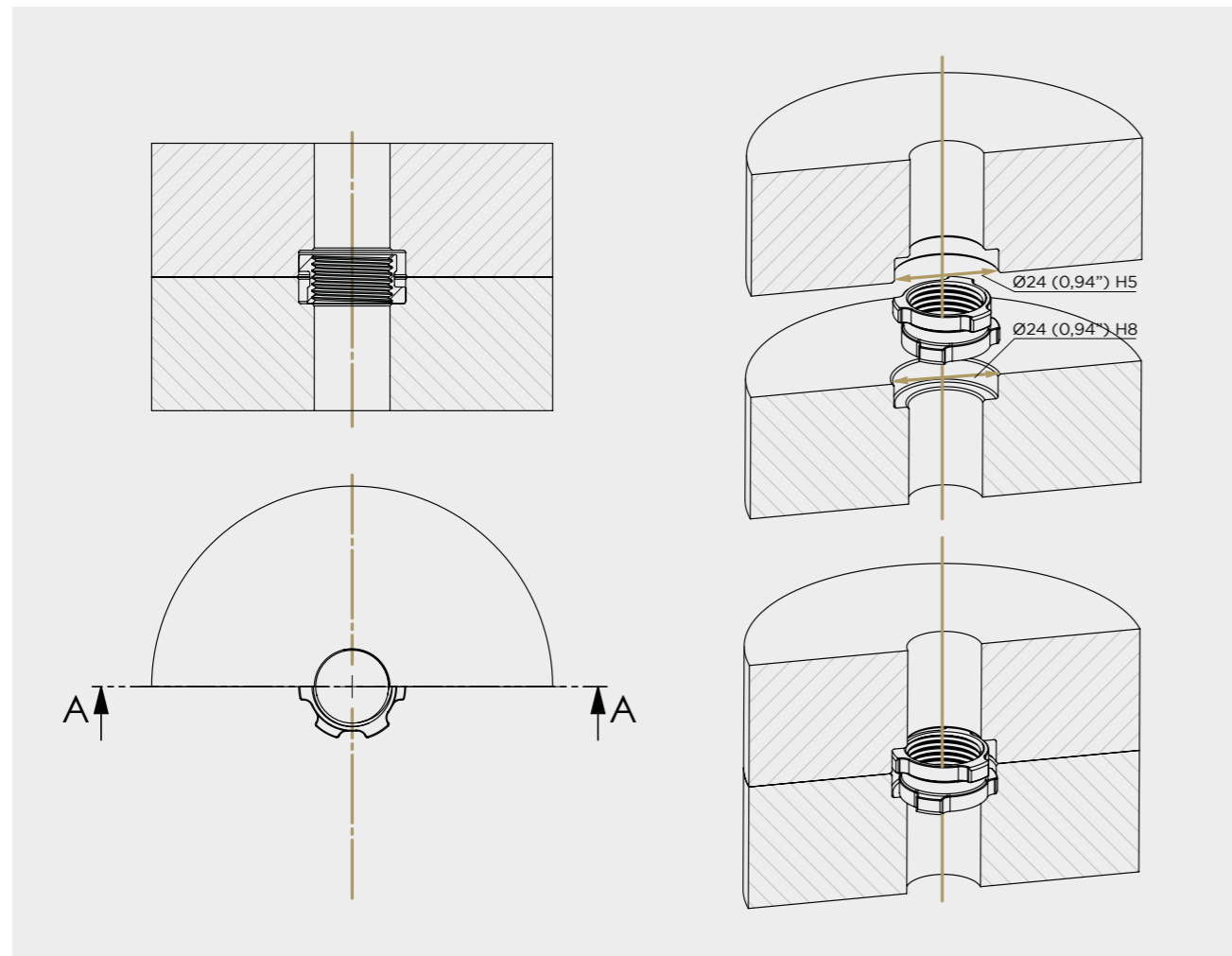
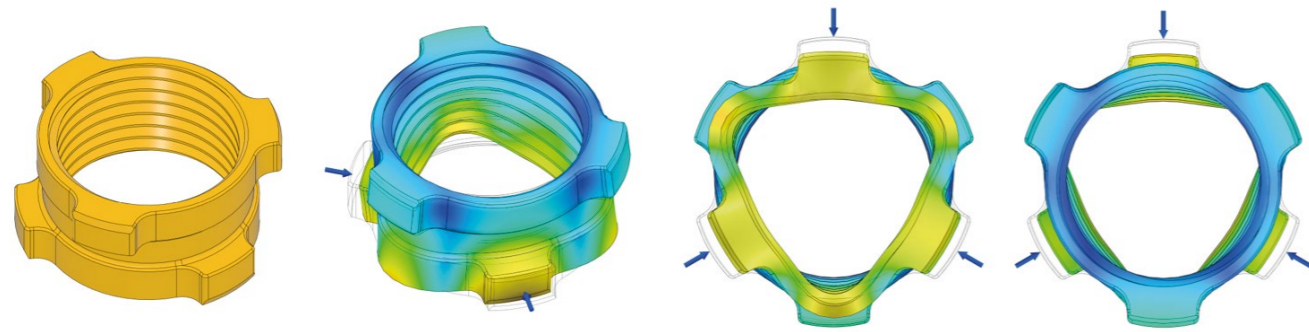

BUSH

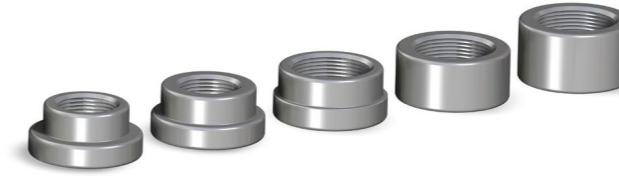

The new PATENTED floating module is designed and created based on specific production needs. It allows you to lock any component, even non-planar or deformed ones, without applying any external force to it, thus guaranteeing its free orientation in space and then allowing it to be solidly locked in the resulting position. It is also possible to accommodate deformations developed during the manufacturing process due to internal tensions of the component or its thermal expansion.

CODE	DESCRIPTION	ØA	ØB	HEIGHT
FM46190924	Standard Bush	24 (0,94")	24 (0,94")	11 (0,43")

CODE	DESCRIPTION	ØA	ØB	H
FM46190925	Bush	24 (0,94")	25 (0,98")	11 (0,43")
FM93000042 *	Bush	24 (0,94")	24 (0,94")	16 (0,23")
FM93000003 *	Bush	24 (0,94")	24 (0,94")	13 (0,51")
FM46190922	Bush	24 (0,94")	22 (0,86")	11 (0,43")
FM46190920	Bush	24 (0,94")	20 (0,78")	11 (0,43")
FM46190918	Bush	24 (0,94")	18 (0,70")	11 (0,43")
FM46190916	Bush	24 (0,94")	16 (0,23")	11 (0,43")
FM46190914	Bush	24 (0,94")	14 (0,55")	11 (0,43")
FM46190912	Bush	24 (0,94")	12 (0,47")	11 (0,43")
FM93000040 **	Bush	36 (1,41")	24 (0,94")	15 (0,59")
FM93000041 **	Bush	36 (1,41")	36 (1,41")	20 (0,78")

* For special applications.
** For vertical clamping.

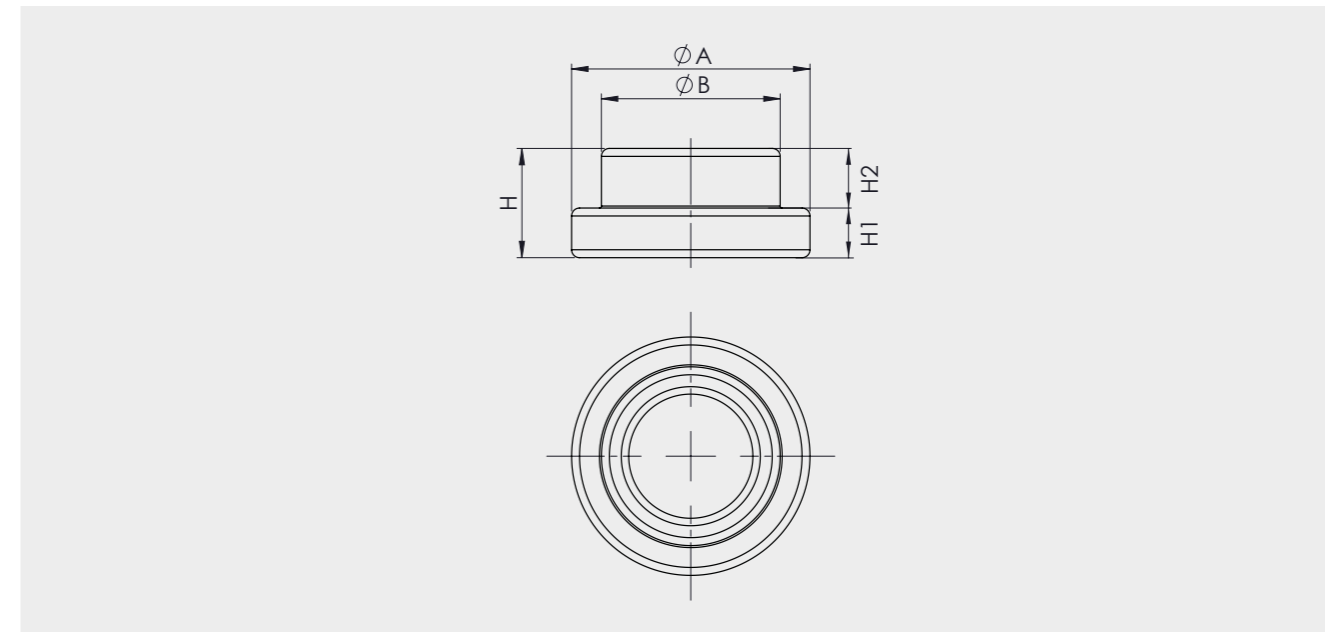

PLATES AND BUSHES
MODULES AND PINS D90
MODULES AND PINS D49
SPACERS
RISERS
THIRD POINT
MAGNETIC
VERTICAL CLAMPING
MINI RANGE
FASTMILL ZERO
CLAMPS

PLATES AND BUSHES
MODULES AND PINS D90
MODULES AND PINS D49
SPACERS
RISERS
THIRD POINT
MAGNETIC
VERTICAL CLAMPING
MINI RANGE
FASTMILL ZERO
CLAMPS

EXAMPLES OF BUSHES

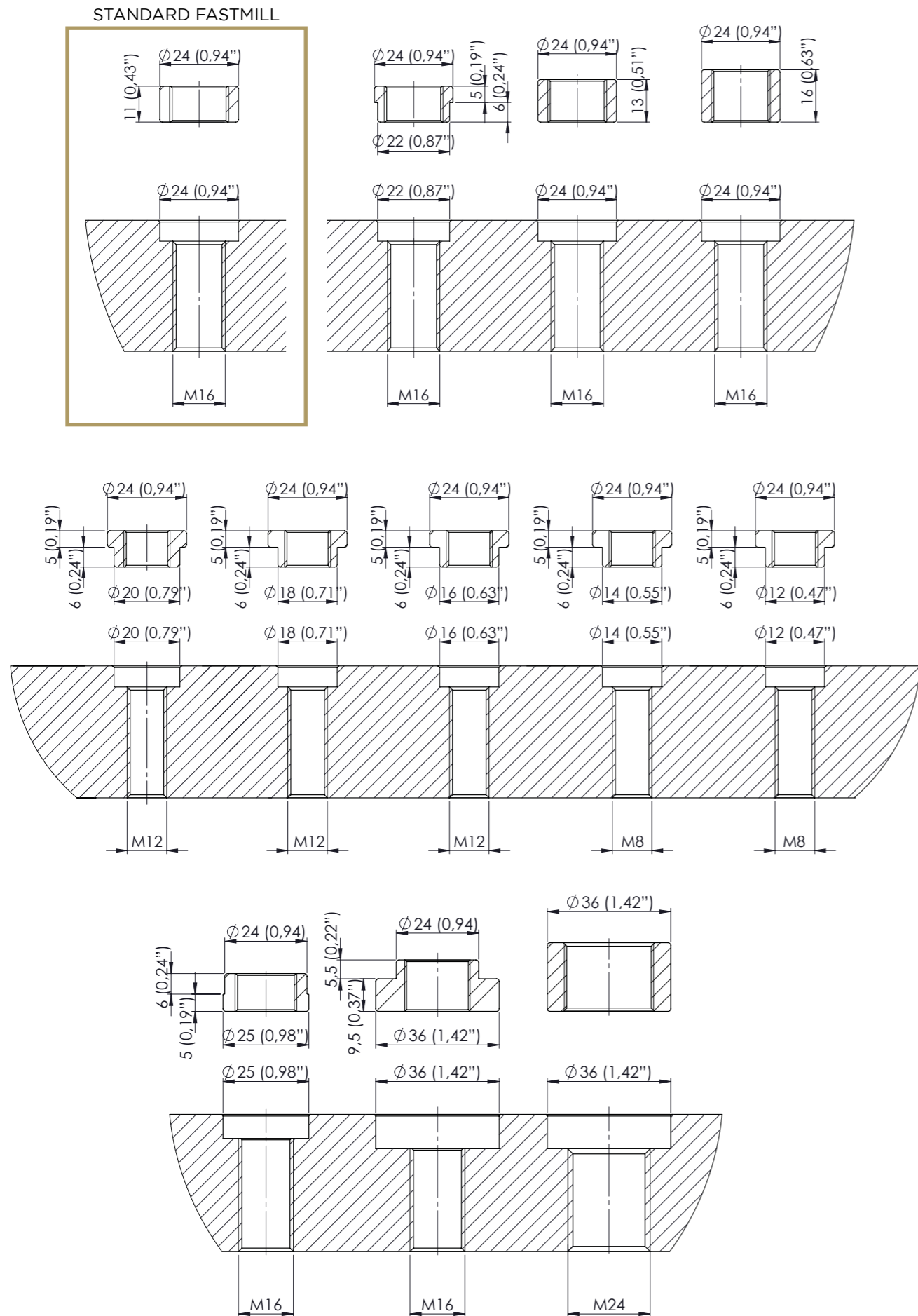

SET FOR MODULAR PLATE ALIGNMENT

Alignment tool with tapered bushings. Allows you to maintain the exact pitch between 2 modular FastMill plates at a pitch between 50mm and 450mm.

CODE	DESCRIPTION	DIMENSION	GRID
FM71290178	Set for modular plate alignment	500x100 (19,6"x3,93")	50 (1,96") / 450 (17,71")

SET CONFIGURATION	N°
Plate for alignment	1 piece
Cones bushes	4 pieces

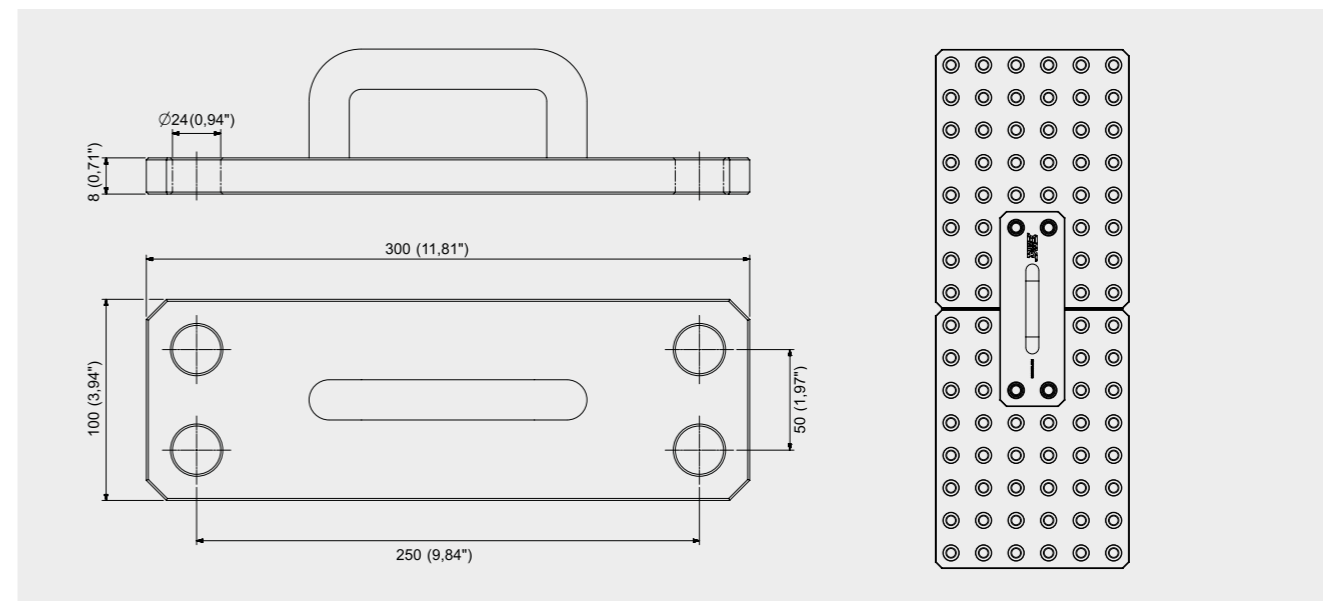

EXTRACTOR ADAPTER PIN AND BUSH EXTRACTOR

Extractor pin used for the removal of FastMill components.
 * Usable with FMZ range.
 ** For vertical clamping.

CODE	DESCRIPTION	DIMENSION
FM46191510	Pin and bush extractor	295 (11,61")

CODE	DESCRIPTION	M
FM46191520	Extractor adapter	M6
FM46191521	Extractor adapter	M8
FM46191522	Extractor adapter	M10
FM46191523 *	Extractor adapter	M14
FM46191525 **	Extractor adapter	M26

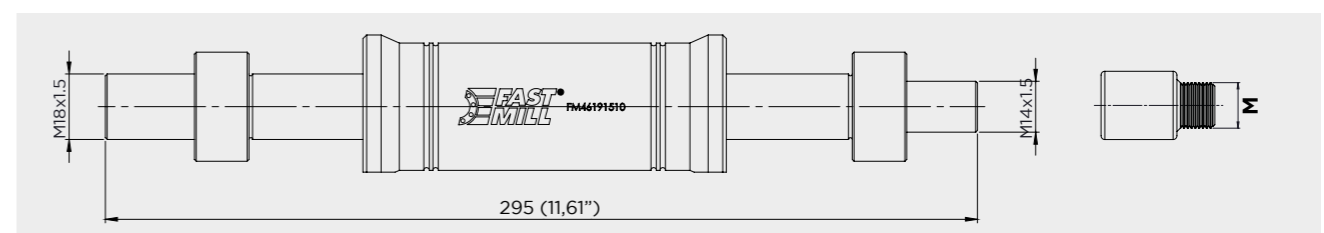

PLATES AND BUSHES
 MODULES AND PINS D90
 MODULES AND PINS D49
 SPACERS
 RISERS
 THIRD POINT
 MAGNETIC
 VERTICAL CLAMPING
 MINI RANGE
 FASTMILL ZERO
 CLAMPS

PLATES AND BUSHES
 MODULES AND PINS D90
 MODULES AND PINS D49
 SPACERS
 RISERS
 THIRD POINT
 MAGNETIC
 VERTICAL CLAMPING
 MINI RANGE
 FASTMILL ZERO
 CLAMPS

PLATES AND BUSHES
 MODULES AND PINS D90
 MODULES AND PINS D49
 SPACERS
 RISERS
 THIRD POINT
 MAGNETIC
 VERTICAL CLAMPING
 MINI RANGE
 FASTMILL ZERO
 CLAMPS

PLATES AND BUSHES
 MODULES AND PINS D90
 MODULES AND PINS D49
 SPACERS
 RISERS
 THIRD POINT
 MAGNETIC
 VERTICAL CLAMPING
 MINI RANGE
 FASTMILL ZERO
 CLAMPS

MODULAR SMART CUBE 500X500

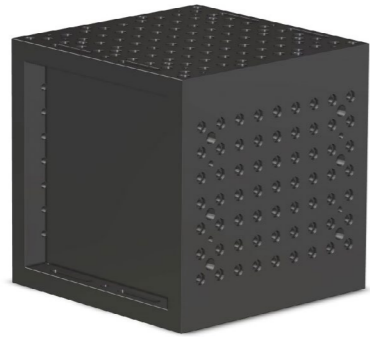

The new 500x500 cube is engineered with versatility in mind, offering a wide range of fixing solutions to meet diverse needs. Its perfectly modular design seamlessly integrates with your workbench, providing a customizable and adaptable workspace. This cube creates a precise reference area for your fixtures, ensuring accuracy and consistency in your projects. Whether for assembly, alignment, or measurement tasks, this cube enhances efficiency by offering a stable and reliable platform that adjusts to your specific requirements.

CODE	DESCRIPTION	DIMENSION	H	WEIGHT
FM57702900	Cube	500x500 (19,6"x19,6")	500 (19,6")	340 kg (749,57 lbs)

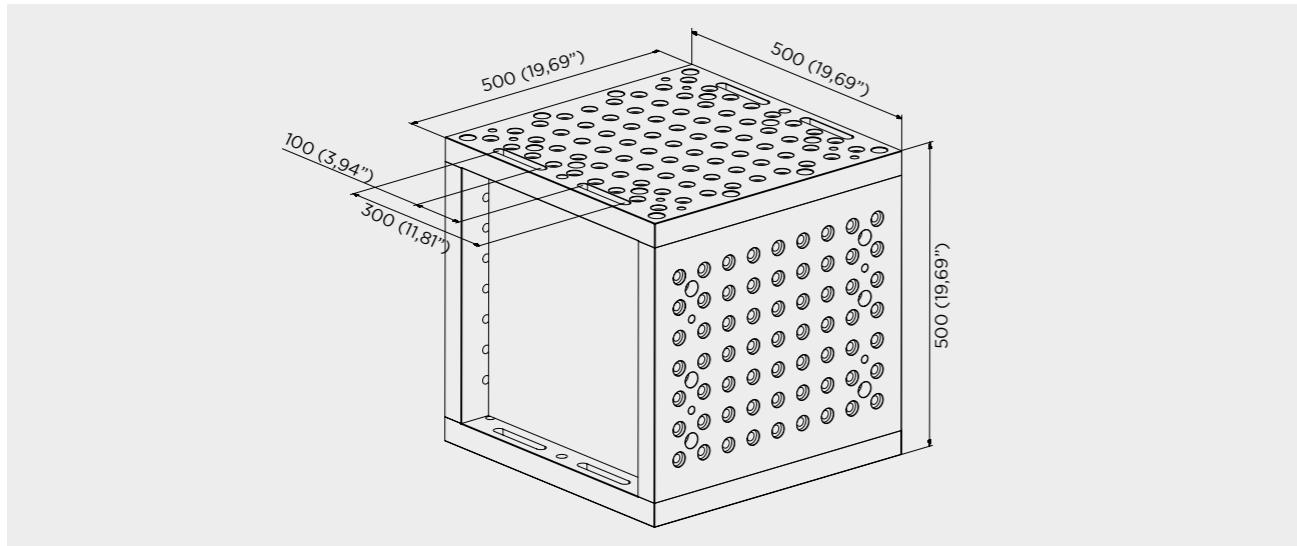

SETUP EXAMPLE

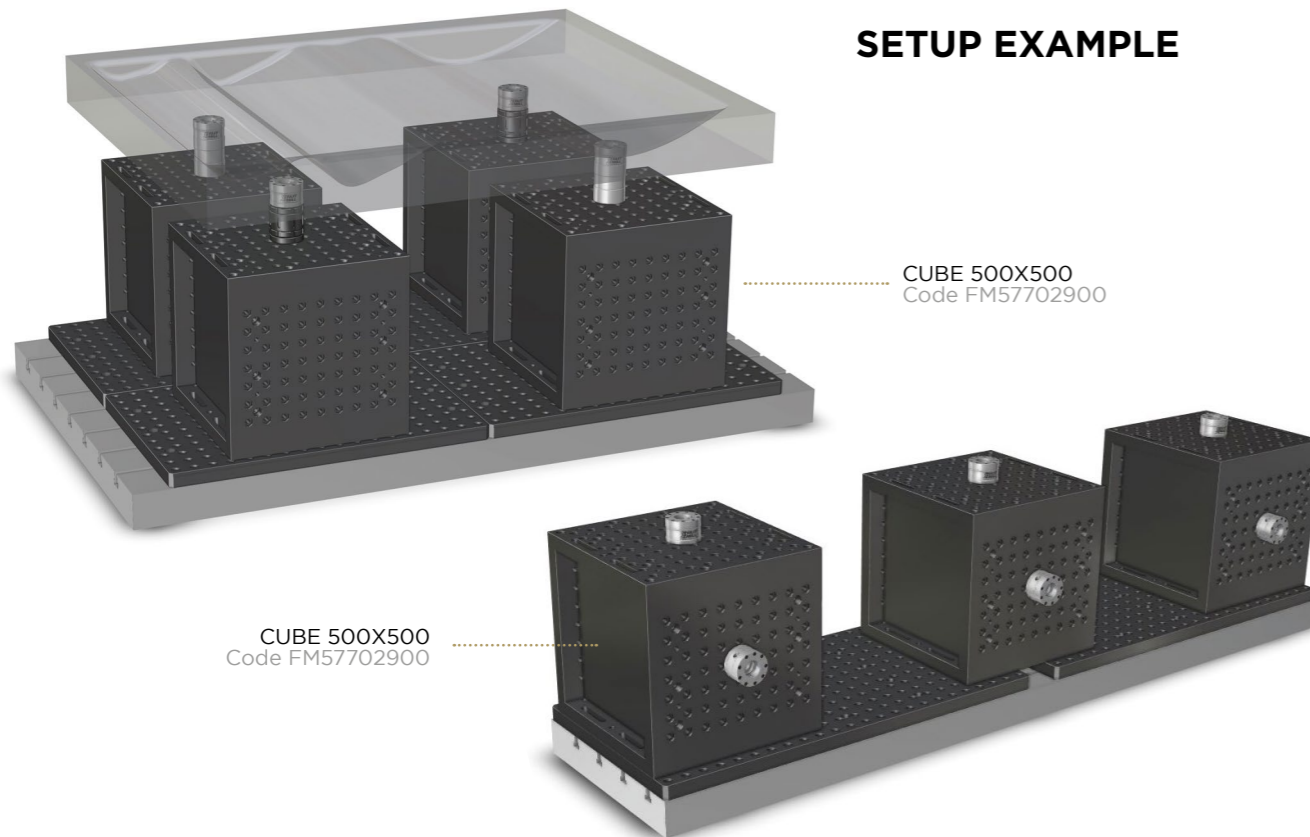

CUBE/TOMBSTONE

FastMill cubes are made to customer specifications and can have one to five faces with a FastMill grid. Can be fixed on T-slots or by modules.

ON DEMAND

Alternative dimensions or custom solutions on demand.

CODE	DESCRIPTION	DIMENSION	H	WEIGHT
FM57700700	Cube/Tombstone	500x500 (19,6"x19,6")	800 (31,4")	597 (1316 lbs)

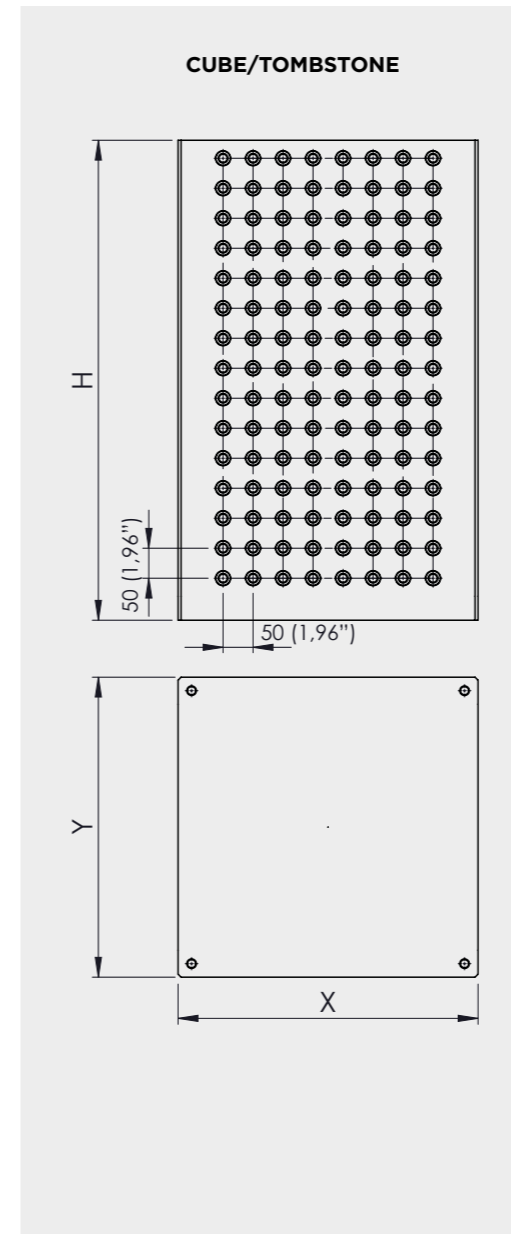

SETUP EXAMPLE

