

CLAMPS	FASTMILL ZERO	MINI RANGE	VERTICAL CLAMPING	MAGNETIC	THIRD POINT	RISERS	SPACERS	MODULES AND PINS D49	MODULES AND PINS D90	PLATES AND BUSHES
--------	---------------	------------	-------------------	----------	-------------	--------	---------	----------------------	----------------------	-------------------

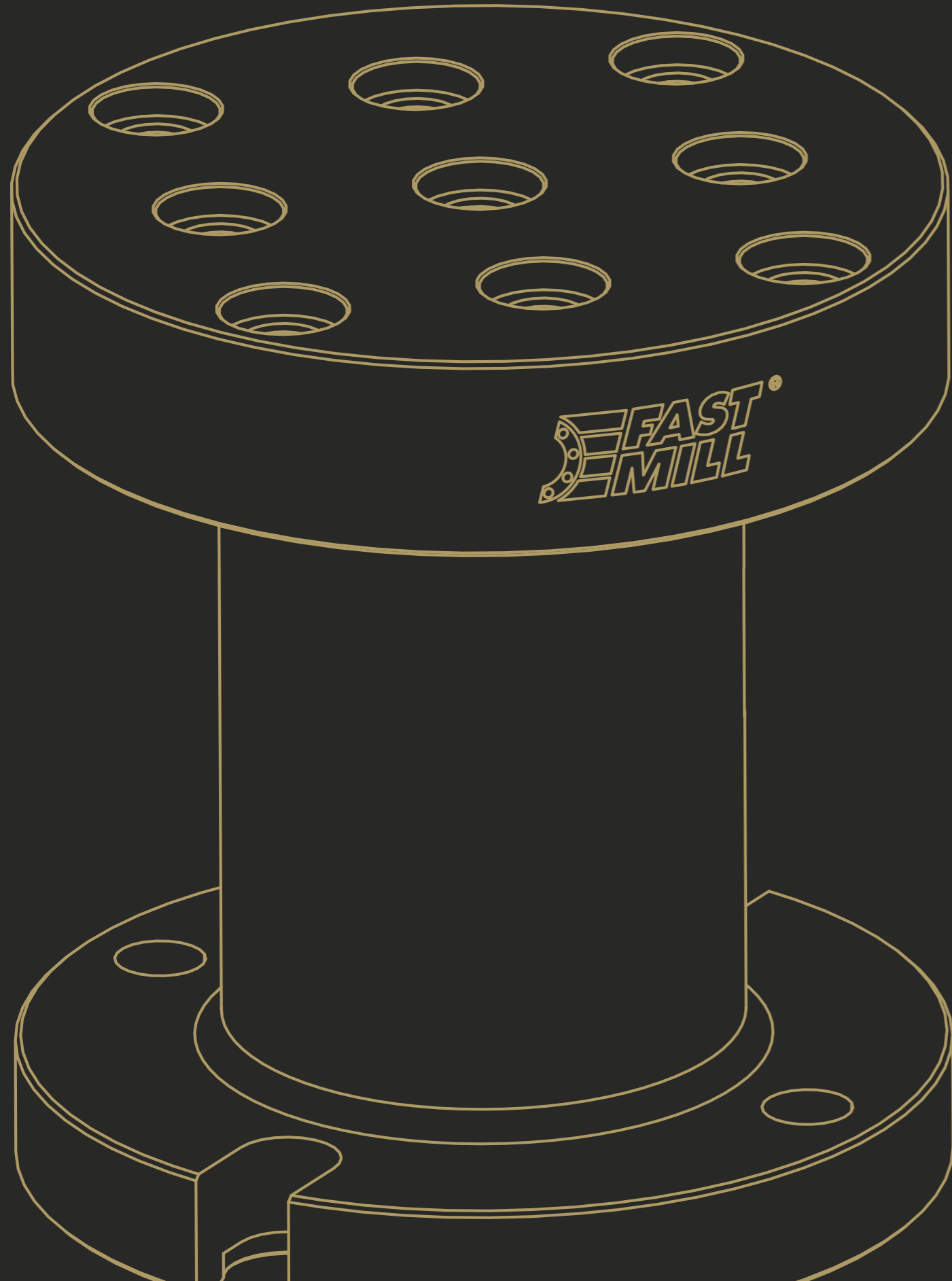

RISERS

CLAMPS	FASTMILL ZERO	MINI RANGE	VERTICAL CLAMPING	MAGNETIC	THIRD POINT	RISERS	SPACERS	MODULES AND PINS D49	MODULES AND PINS D90	PLATES AND BUSHES
--------	---------------	------------	-------------------	----------	-------------	--------	---------	----------------------	----------------------	-------------------



RISERS Ø135 - Ø175

The FastMill riser range is used to raise the entire clamping set up in the Z direction while maintaining a solid support surface. Thanks to the precise centering, the position of the counterbore corresponds to that of the FastMill plate on which the riser is mounted. Available in two sizes and diameters to cover all needs

CODE	DESCRIPTION	Ø	HEIGHT	WEIGHT
FM46192060	Riser	135 (5,31")	160 (6,29")	13 (28,66 lbs)
FM46192050	Riser	175 (6,88")	200 (7,87")	20 (44,09 lbs)

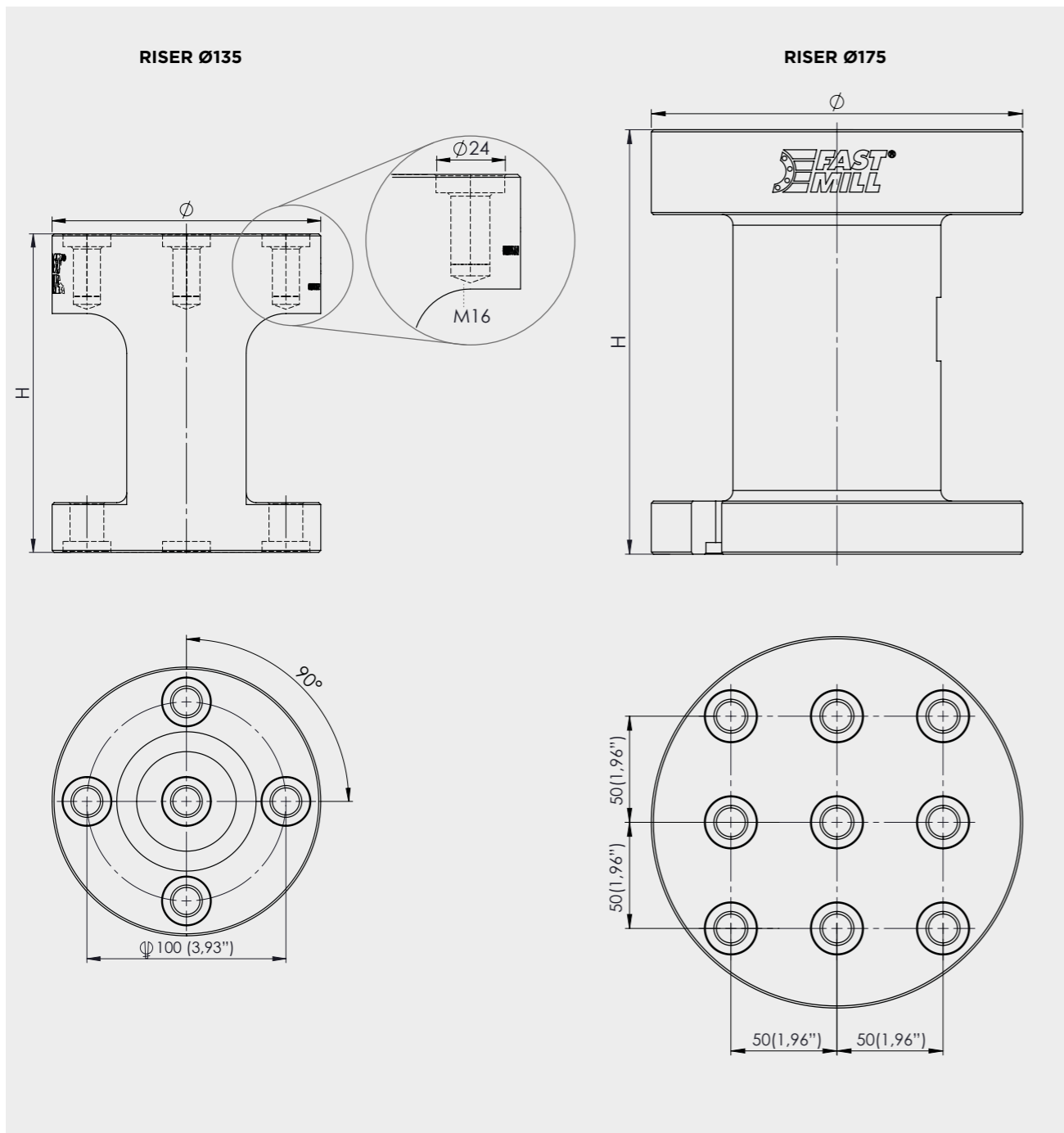

RISER ASSEMBLY EXAMPLE

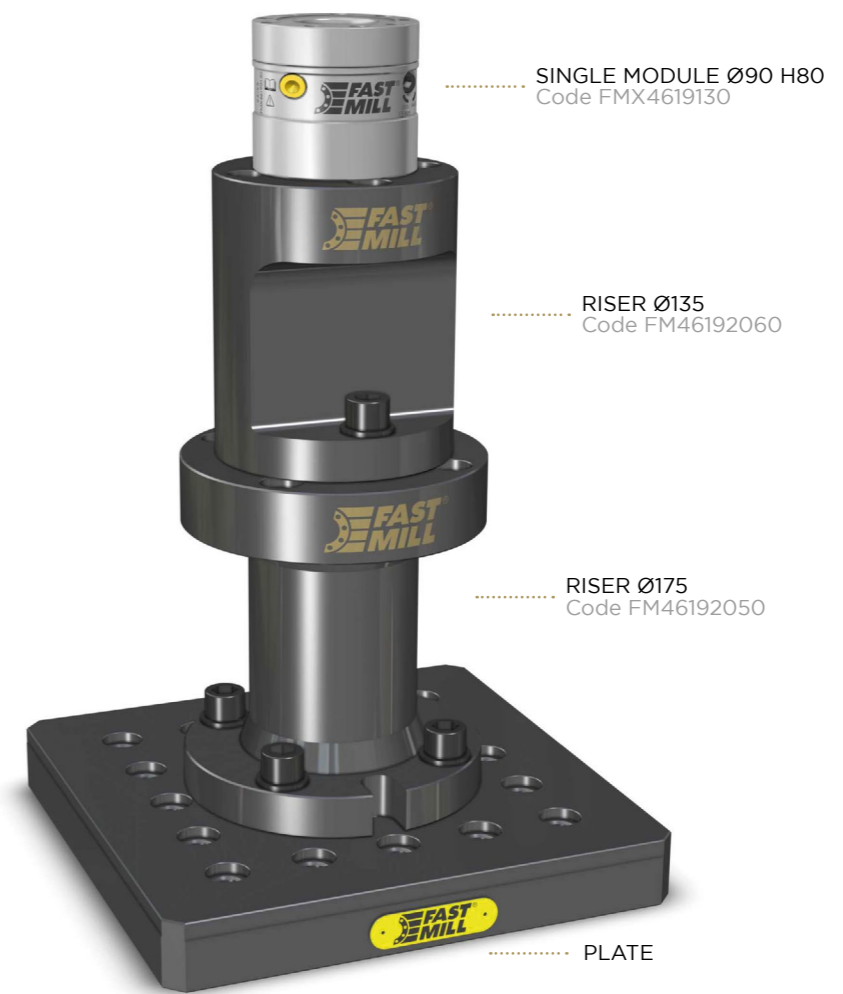

RISER ASSEMBLY EXAMPLE

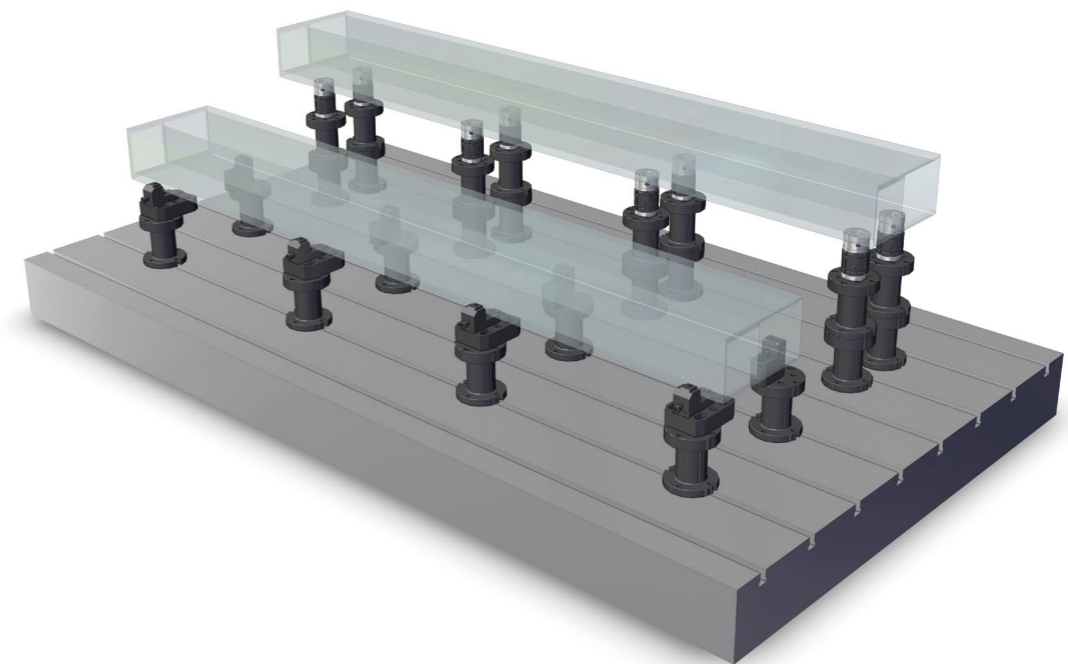

PLATES AND BUSHES
MODULES AND PINS D90
MODULES AND PINS D49
SPACERS
RISERS
THIRD POINT
MAGNETIC
VERTICAL CLAMPING
MINI RANGE
FASTMILL ZERO
CLAMPS

PLATES AND BUSHES
MODULES AND PINS D90
MODULES AND PINS D49
SPACERS
RISERS
THIRD POINT
MAGNETIC
VERTICAL CLAMPING
MINI RANGE
FASTMILL ZERO
CLAMPS