

| | | | | | | | | | | |
|-------------------|----------------------|----------------------|---------|--------|-------------|----------|-------------------|------------|---------------|--------|
| PLATES AND BUSHES | MODULES AND PINS D90 | MODULES AND PINS D49 | SPACERS | RISERS | THIRD POINT | MAGNETIC | VERTICAL CLAMPING | MINI RANGE | FASTMILL ZERO | CLAMPS |
|-------------------|----------------------|----------------------|---------|--------|-------------|----------|-------------------|------------|---------------|--------|

VERTICAL CLAMPING

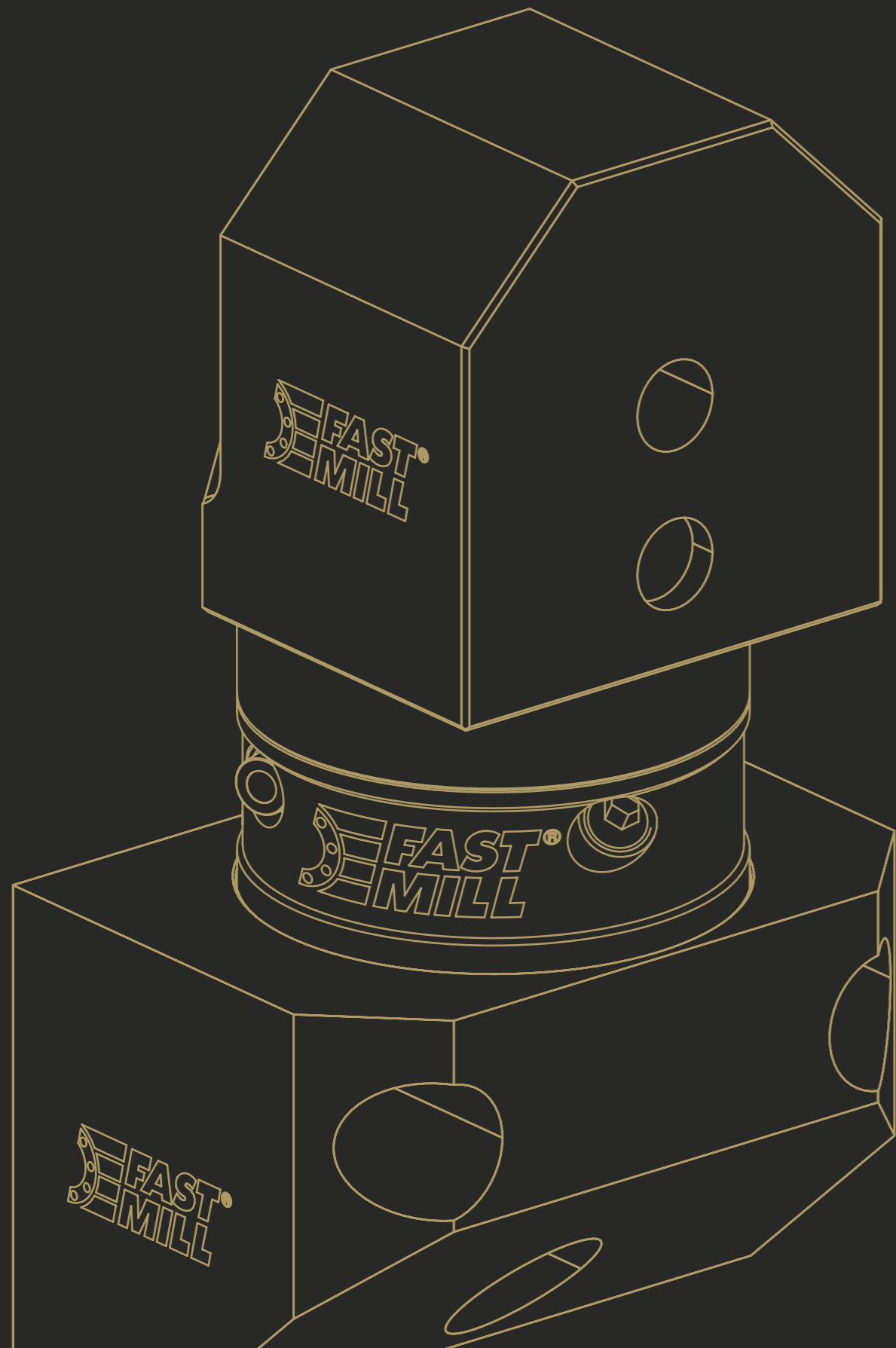



VERTICAL CLAMPING AND POSITIONING SET

Vertical clamping and positioning system allows a vertical type of fixing on medium-sized components, while ensuring a known position of the piece with respect to space. The system works using our standard Fastmill modules to which appropriate accessories are applied for vertical assembly. A lateral fixing accessory is also available in cases with no possibility of fixing on the back of the workpiece.

| CODE | |
|--------------|-------------------------------------------------------------|
| FMVCA0016024 | Vertical clamping and positioning set (module not included) |

| SET CONFIGURATION | N° |
|------------------------------------|----------|
| Bush Ø24-24 mm | 6 pieces |
| TCEI M16X60 mm UNI 5931-12,9 screw | 3 pieces |
| TCEI M16X40 mm UNI 5931-12,9 screw | 1 piece |
| TCEI M16X20 mm UNI 5931-12,9 screw | 1 piece |
| TE M16X100 mm UNI 5739-12,9 screw | 1 piece |
| Feather key 28X16X60 DIN6885 C | 1 piece |
| 7x30 UNI 6592-69 washer | 1 piece |



90° LATERAL CLAMPING ACCESSORIES

| CODE | DESCRIPTION | DIMENSION | HEIGHT | WEIGHT |
|---------------|----------------------------------|---------------------|-------------|----------------|
| FMVCHPLATERAL | 90° Lateral clamping accessories | 98x60 (3,85"x2,36") | 110 (4,33") | 2,7 (5,95 lbs) |

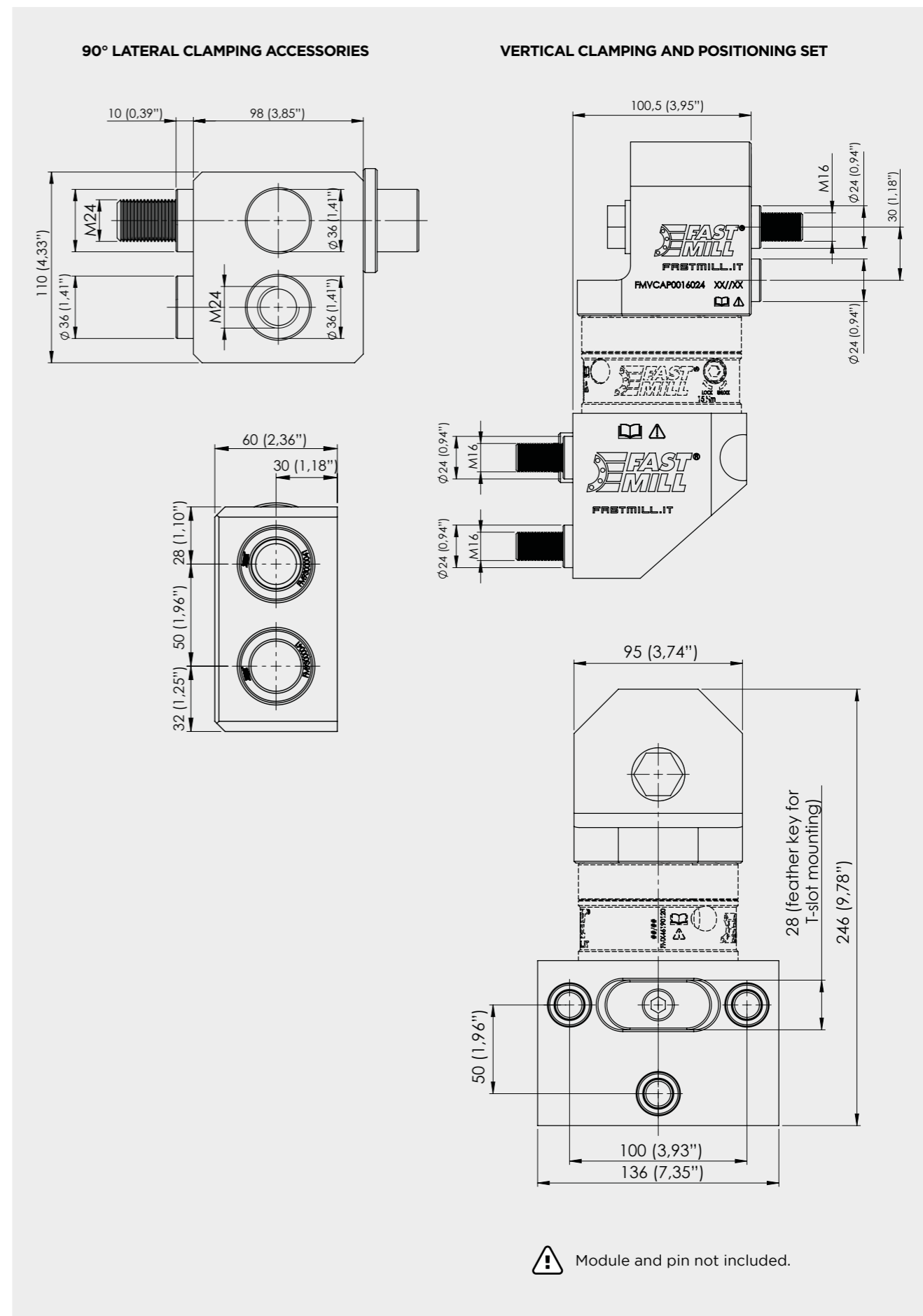

PLATES AND BUSHES
MODULES AND PINS D90
MODULES AND PINS D49
SPACERS
RISERS
THIRD POINT
MAGNETIC
VERTICAL CLAMPING
MINI RANGE
FASTMILL ZERO
CLAMPS

PLATES AND BUSHES
MODULES AND PINS D90
MODULES AND PINS D49
SPACERS
RISERS
THIRD POINT
MAGNETIC
VERTICAL CLAMPING
MINI RANGE
FASTMILL ZERO
CLAMPS

SETUP EXAMPLE

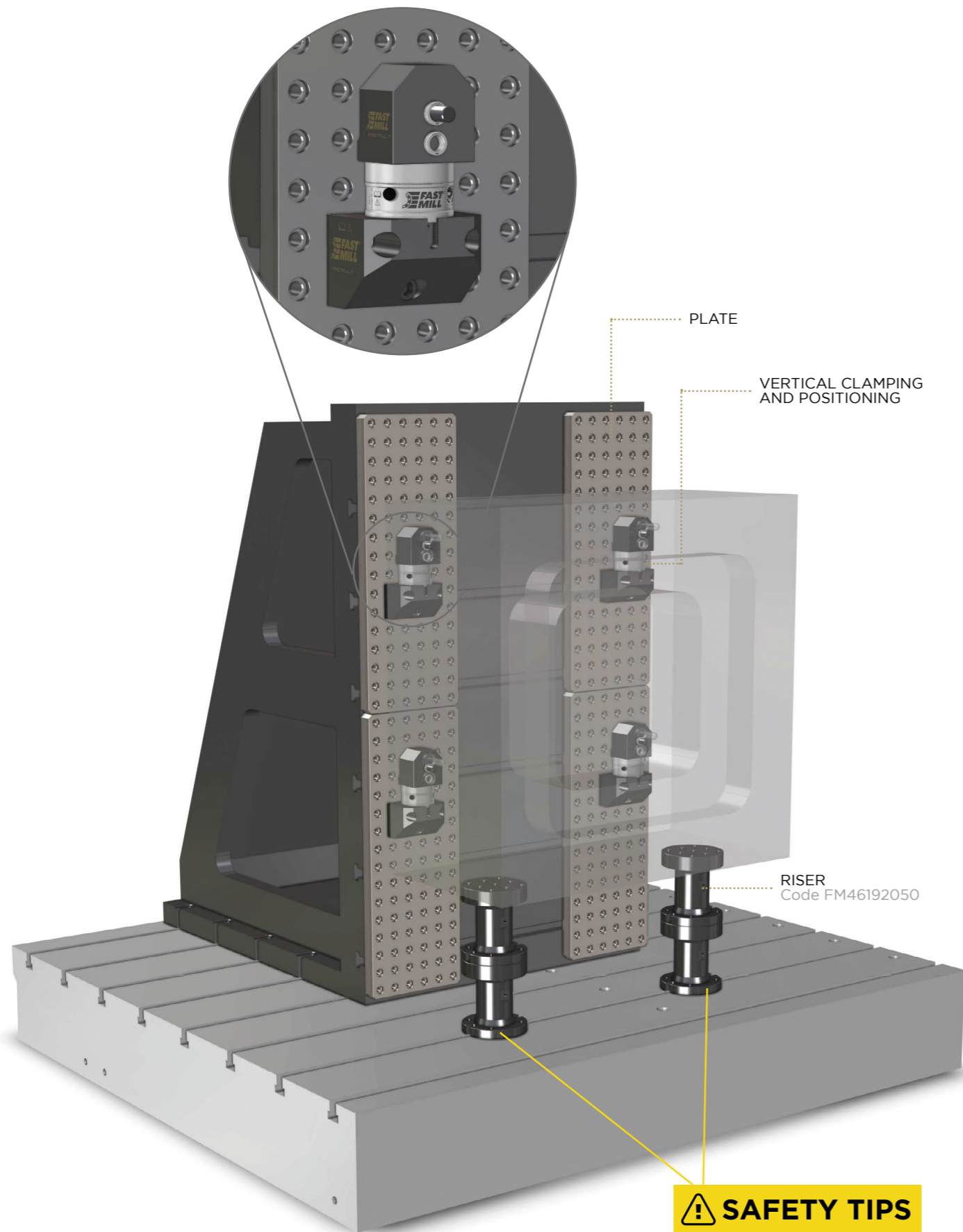

! SAFETY TIPS

90° INDEX RISER SET

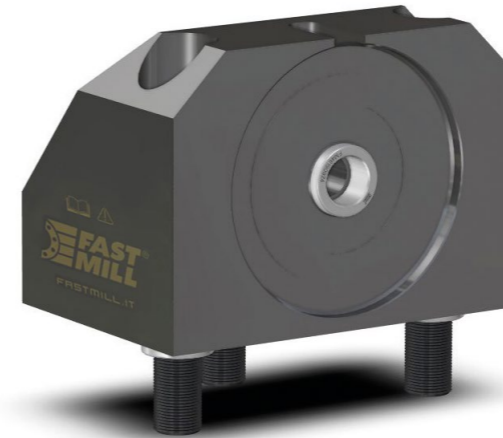

90° Index riser set is an accessory able to quickly mount a module in a vertical position, thus expanding the possibility of machining on 3-axis machines or for any particular needs and also comes with a removable key for use with standard modules and indexed modules.

| CODE | DESCRIPTION |
|---------------|---------------------|
| FM90IR0016024 | 90° Index riser set |

| SET CONFIGURATION | N° |
|------------------------------------|----------|
| Eather key 12H6X8X30 for index | 1 piece |
| Bush Ø24-24 mm | 5 pieces |
| TCEI M4X10 mm UNI 5931 inox screw | 1 piece |
| TCEI M16X60 mm UNI 5931-12,9 screw | 3 pieces |

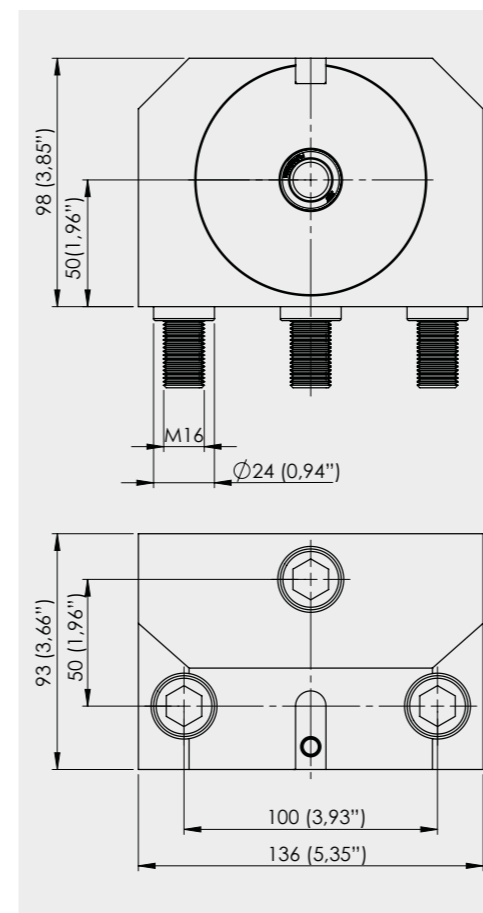

SETUP EXAMPLE

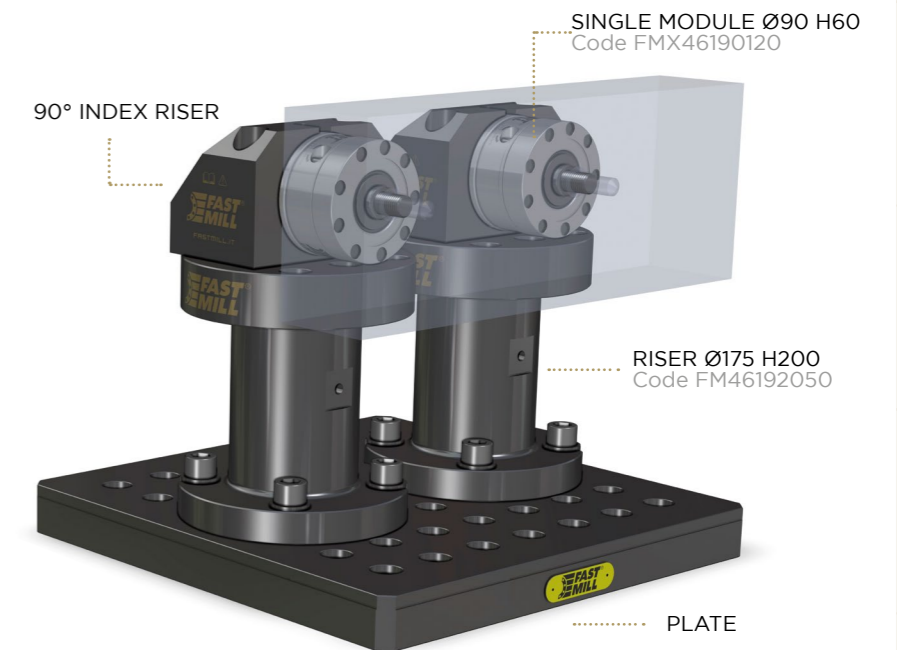

PLATES AND BUSHES
MODULES AND PINS D90
MODULES AND PINS D49
SPACERS
RISERS
THIRD POINT
MAGNETIC
VERTICAL CLAMPING
MINI RANGE
FASTMILL ZERO
CLAMPS

PLATES AND BUSHES
MODULES AND PINS D90
MODULES AND PINS D49
SPACERS
RISERS
THIRD POINT
MAGNETIC
VERTICAL CLAMPING
MINI RANGE
FASTMILL ZERO
CLAMPS