

CLAMPS

FASTMILL ZERO

MINI RANGE

VERTICAL CLAMPING

MAGNETIC

THIRD POINT

RISERS

SPACERS

MODULES AND PINS D49

MODULES AND PINS D90

PLATES AND BUSHES

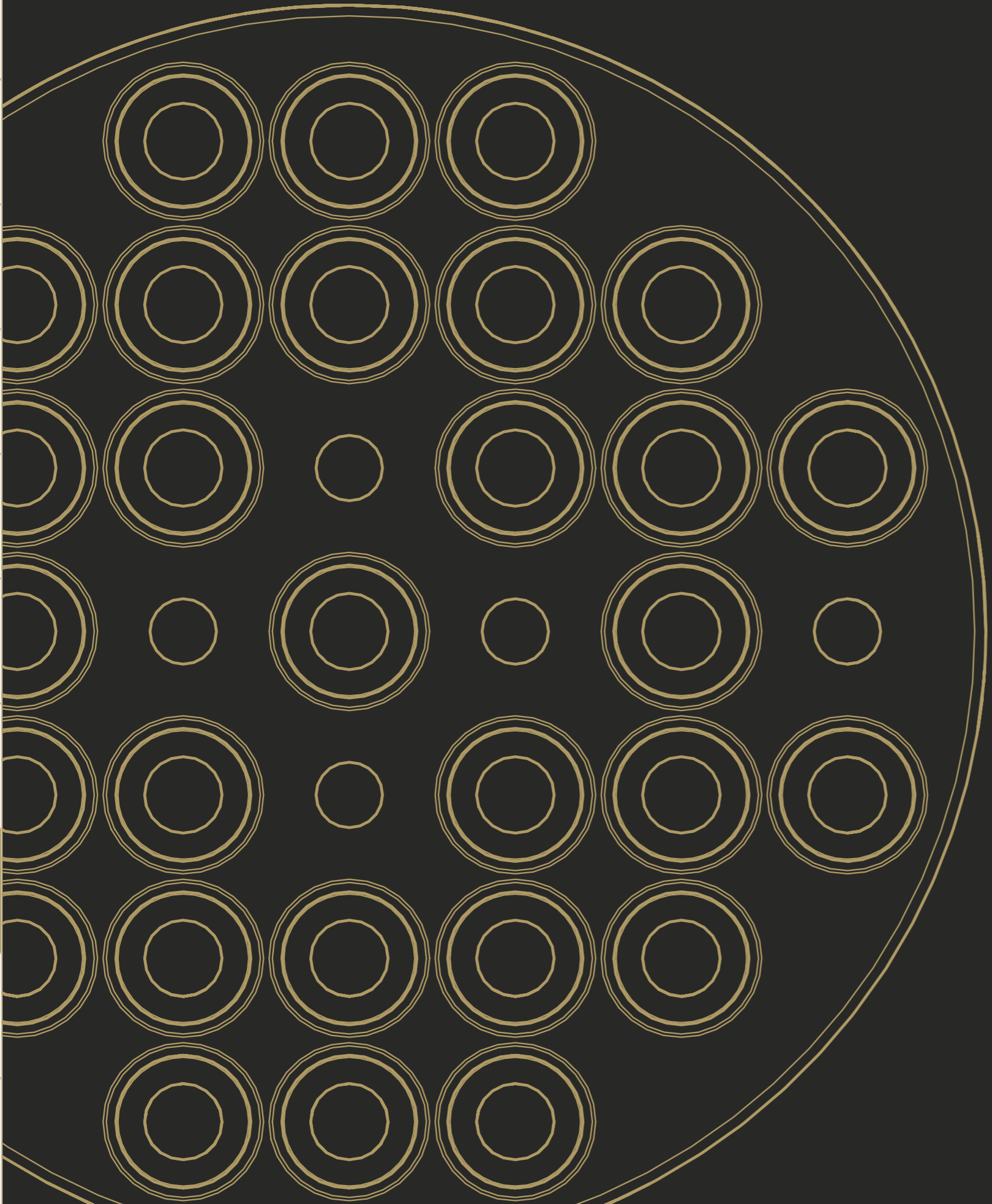

MINI RANGE

CLAMPS

FASTMILL ZERO

MINI RANGE

VERTICAL CLAMPING

MAGNETIC

THIRD POINT

RISERS

SPACERS

MODULES AND PINS D49

MODULES AND PINS D90

PLATES AND BUSHES



PALLET

FastMill pallets allow to hold small and medium-sized components. Made of pre-treated stainless steel, they offer great rigidity which allowing to obtain finishes with very low roughness. Prepared for precision clamping, they allow the machining of the components, on 5 free faces, optimizing work cycle and minimizing machine stops.

Introducing the all-new Mini Range M4 collection: a complete lineup of pallets, pins, and spacers with minimal dimensions, specifically designed for securing small parts with precision. The range also includes the innovative Plug, which ensures consistent reference points across multiple positionings, enhancing accuracy and efficiency in your work.

M4 WORKPIECE FIXING SCREW

| CODE | XxY | H | PxP | X1xY1 | N° MODULES REQUIRED | REQUIRED FOR ASSEMBLY |
|------------|---------------------|------------|------------|-----------------|---------------------|--|
| FM46195028 | 160x100 (6,3"x3,9") | 36 (1,41") | 10 (0,39") | 100x0 (3,93"x0) | 2 |  No. 2 Male pin M8 Ø12 |

M6 WORKPIECE FIXING SCREW

| CODE | XxY | H | PxP | X1xY1 | N° MODULES REQUIRED | REQUIRED FOR ASSEMBLY |
|------------|-------------------------|------------|------------|------------------------|---------------------|--|
| FM46195020 | 196x196 (7,71"x7,71") | 36 (1,41") | 15 (0,59") | 100x0 (3,93"x0) | 2* |  *No. 2 Male pin M12 Ø20 No. 4 Male pin M12 Ø20 |
| FM46195021 | 246x246 (9,68"x9,68") | 36 (1,41") | 15 (0,59") | 100x100 (3,93"x 3,93") | 4 | |
| FM46195022 | 296x296 (11,65"x11,65") | 36 (1,41") | 15 (0,59") | 200x200 (7,87"x 7,87") | 4 | |

M8 WORKPIECE FIXING SCREW

| CODE | XxY | H | PxP | X1xY1 | N° MODULES REQUIRED | REQUIRED FOR ASSEMBLY |
|------------|-------------------------|------------|------------|------------------------|---------------------|---|
| FM46195025 | 246x246 (9,68"x9,68") | 36 (1,41") | 20 (0,78") | 100x100 (3,93"x 3,93") | 4 |  No. 4 Male pin M12 Ø20 |
| FM46195026 | 296x296 (11,65"x11,65") | 36 (1,41") | 20 (0,78") | 200x200 (7,87"x 7,87") | 4 | |

M10 WORKPIECE FIXING SCREW

| CODE | XxY | H | PxP | X1xY1 | N° MODULES REQUIRED | REQUIRED FOR ASSEMBLY |
|------------|-------------------------|------------|------------|------------------------|---------------------|---|
| FM46195029 | 246x246 (9,68"x9,68") | 46 (1,81") | 25 (0,98") | 150x150 (5,90"x 3,93") | 4 |  No. 4 Male pin M16 Ø24 |
| FM46195030 | 296x296 (11,65"x11,65") | 46 (1,81") | 25 (0,98") | 200x200 (7,87"x 7,87") | 4 | |

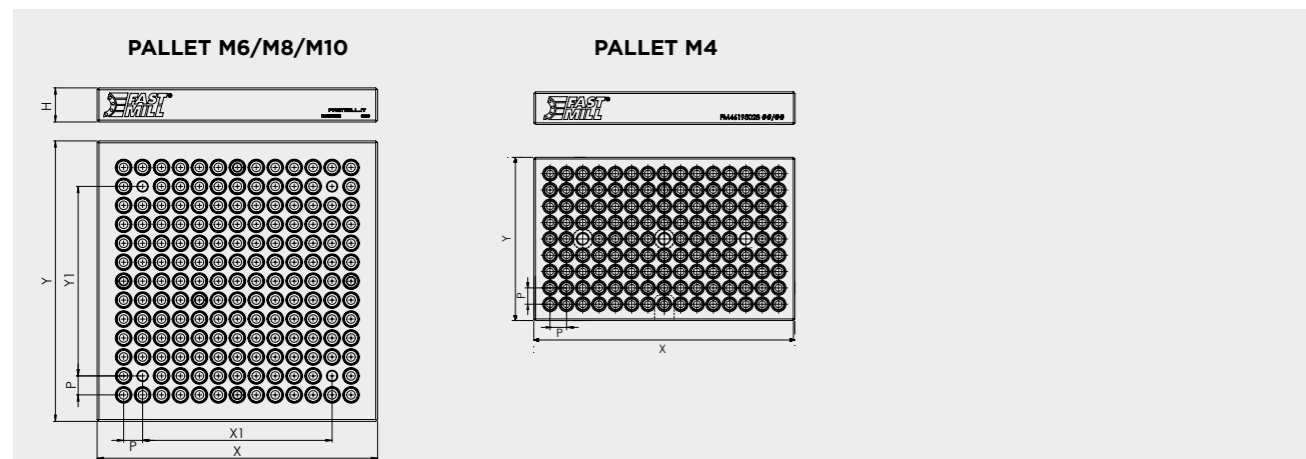

PALLET ASSEMBLY EXAMPLE

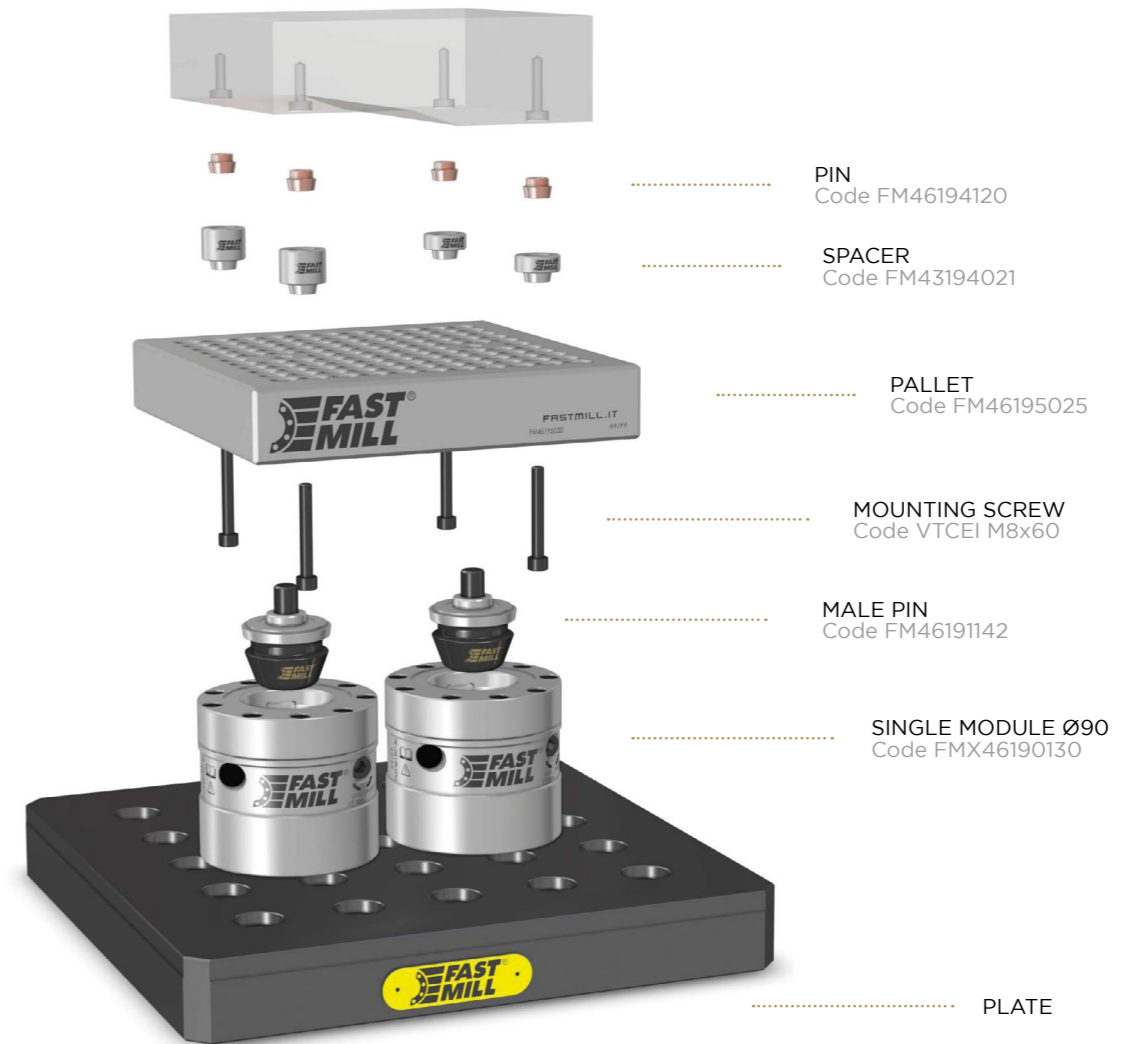

PALLET ASSEMBLY EXAMPLE

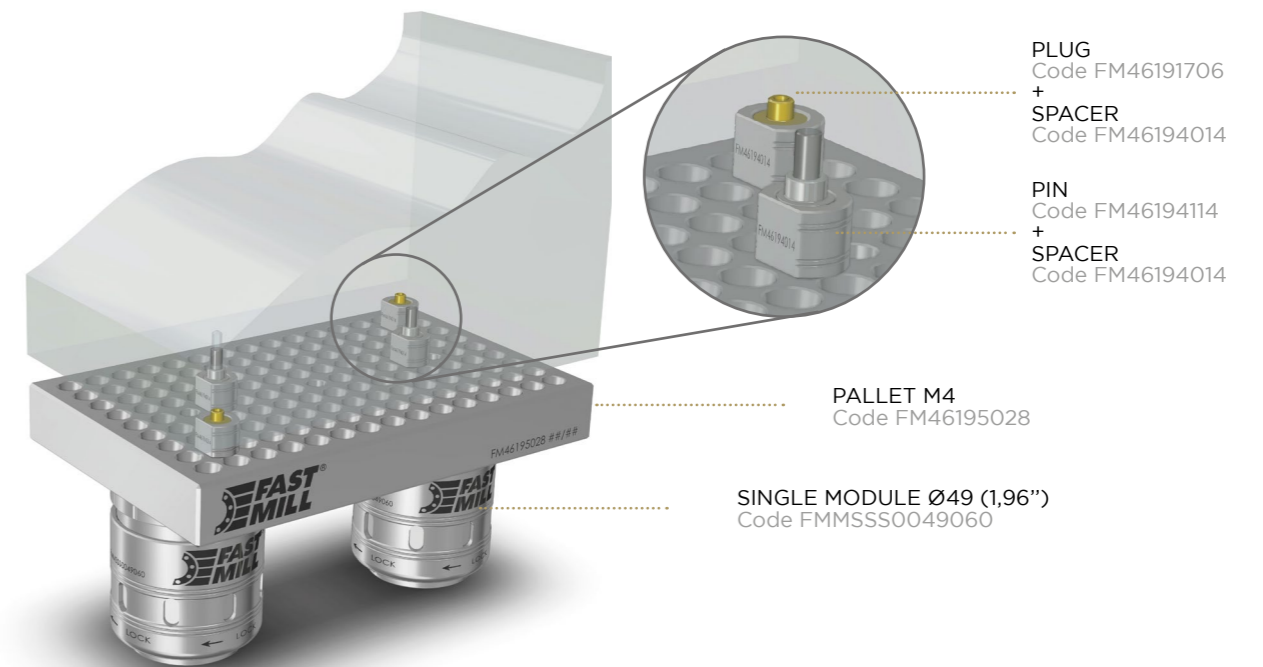

PLATES AND BUSHES
 MODULES AND PINS D90
 MODULES AND PINS D49
 SPACERS
 RISERS
 THIRD POINT
 MAGNETIC
 VERTICAL CLAMPING
 MINI RANGE
 FASTMILL ZERO
 CLAMPS

PLATES AND BUSHES
 MODULES AND PINS D90
 MODULES AND PINS D49
 SPACERS
 RISERS
 THIRD POINT
 MAGNETIC
 VERTICAL CLAMPING
 MINI RANGE
 FASTMILL ZERO
 CLAMPS



COATED PIN SPACER

FastMill coated pins are used to ensure precise alignment between the pallet and the workpieces. Assembled with FastMill Spacers, they offer the ability to raise the workpiece allowing the CNC to reach all the work areas freely.



Related extractor adapter at pag.13

M4 COATED PIN AND SPACER

| CODE | DESCRIPTION | DIMENSION | HEIGHT | WEIGHT |
|------------|----------------|----------------|--------------|---------|
| FM46194014 | Spacer | Ø 13,5 (0,53") | 10 (0,39") | 0,01 Kg |
| FM46194114 | Coated Pin | Ø 6 (0,23") | 7,25 (0,28") | 0,01 Kg |
| FM46191706 | Plug alignment | Ø 4 (0,15") | 7,25 (0,28") | 0,01 Kg |

M6 COATED PIN AND SPACER

| CODE | DESCRIPTION | SCREW | ØA | ØB | HEIGHT |
|------------|-------------|-------|------------|------------|------------|
| FM46194115 | Coated Pin | M6 | 10 (0,39") | - | |
| FM46194110 | Coated Pin | M6 | 11 (0,43") | - | |
| FM46194011 | Spacer | M6 | - | 22 (0,86") | 8 (0,31") |
| FM46194012 | Spacer | M6 | - | 22 (0,86") | 12 (0,47") |
| FM46194013 | Spacer | M6 | - | 22 (0,86") | 16 (0,62") |

M8 COATED PIN AND SPACER

| CODE | DESCRIPTION | SCREW | ØA | ØB | HEIGHT |
|------------|-------------|-------|------------|------------|------------|
| FM46194125 | Coated Pin | M8 | 12 (0,47") | - | |
| FM46194120 | Coated Pin | M8 | 14 (0,55") | - | |
| FM46194021 | Spacer | M8 | - | 25 (0,98") | 10 (0,39") |
| FM46194022 | Spacer | M8 | - | 25 (0,98") | 15 (0,59") |
| FM46194023 | Spacer | M8 | - | 25 (0,98") | 20 (0,78") |

M10 COATED PIN AND SPACER

| CODE | DESCRIPTION | SCREW | ØA | ØB | HEIGHT |
|------------|-------------|-------|------------|------------|------------|
| FM46194135 | Coated Pin | M10 | 14 (0,55") | - | |
| FM46194130 | Coated Pin | M10 | 16 (0,62") | - | |
| FM46194031 | Spacer | M10 | - | 28 (1,10") | 15 (0,59") |
| FM46194032 | Spacer | M10 | - | 28 (1,10") | 25 (0,98") |
| FM46194033 | Spacer | M10 | - | 28 (1,10") | 35 (1,37") |

COATED PIN AND SPACER EXAMPLE

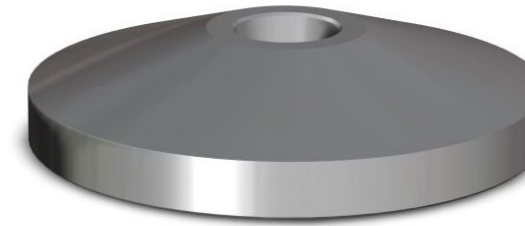
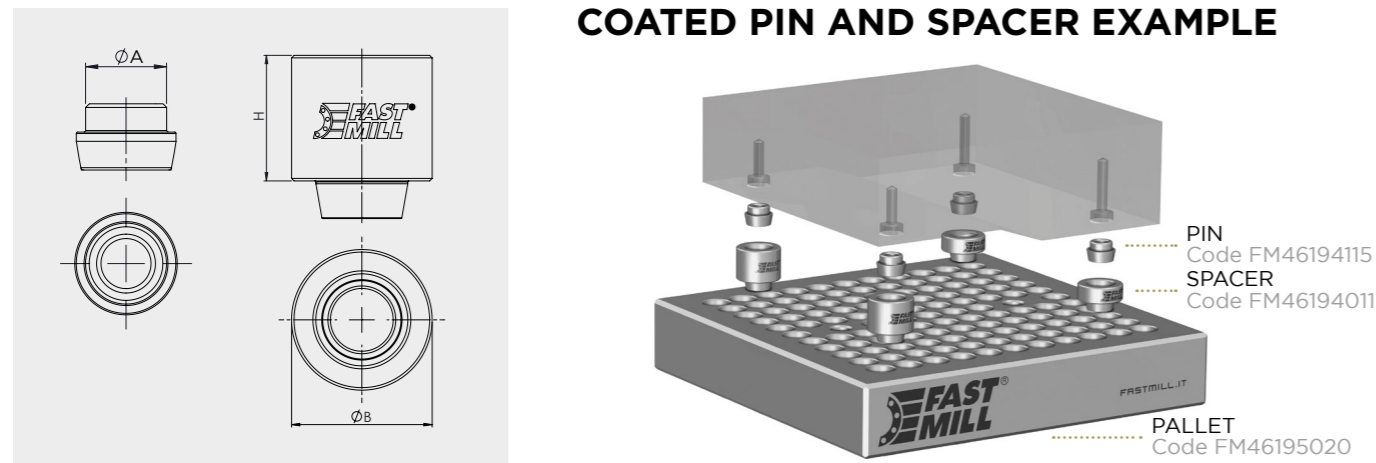

ADAPTER FOR Ø90 MODULE

Adapter for module offers the possibility to fix small workpieces directly on the modules by using mini range pins and spacers. It guarantees a fast and flexible workpiece change.

| CODE | DESCRIPTION | A | B | C | WEIGHT |
|------------|--------------------|--------------|--------------|----------------------------------|-------------------|
| FM46194000 | Adapter for module | Ø 20 (0,78") | Ø 11 (0,43") | COATED PIN AND SPACER M6 | 0,5 kg (1,10 lbs) |
| FM46194003 | Adapter for module | Ø 20 (0,78") | Ø 13 (0,51") | COATED PIN AND SPACER M8 | 0,5 kg (1,10 lbs) |
| FM46194006 | Adapter for module | Ø 20 (0,78") | Ø 15 (0,59") | COATED PIN AND SPACER M10 | 0,5 kg (1,10 lbs) |



ADAPTER FOR Ø49 MODULE

The adapter is an accessory that expands the range of use of FastMill modules. It allows you to use the Mini Range components mounted on top of the D49 module thanks to its interface. Useful for clamping where space on the workpiece is extremely limited.

| CODE | DESCRIPTION | A | B | C | WEIGHT |
|------------|-----------------------|--------------|---------------|----------------------------------|-------------------|
| FM46194100 | Adapter for 49 module | Ø 11 (0,43") | Ø 7 (0,28") | COATED PIN AND SPACER M6 | 0,5 kg (1,10 lbs) |
| FM46194103 | Adapter for 49 module | Ø 14 (0,55") | Ø 8,5 (0,33") | COATED PIN AND SPACER M8 | 0,5 kg (1,10 lbs) |
| FM46194106 | Adapter for 49 module | Ø 16 (0,63") | Ø 11 (0,43") | COATED PIN AND SPACER M10 | 0,5 kg (1,10 lbs) |

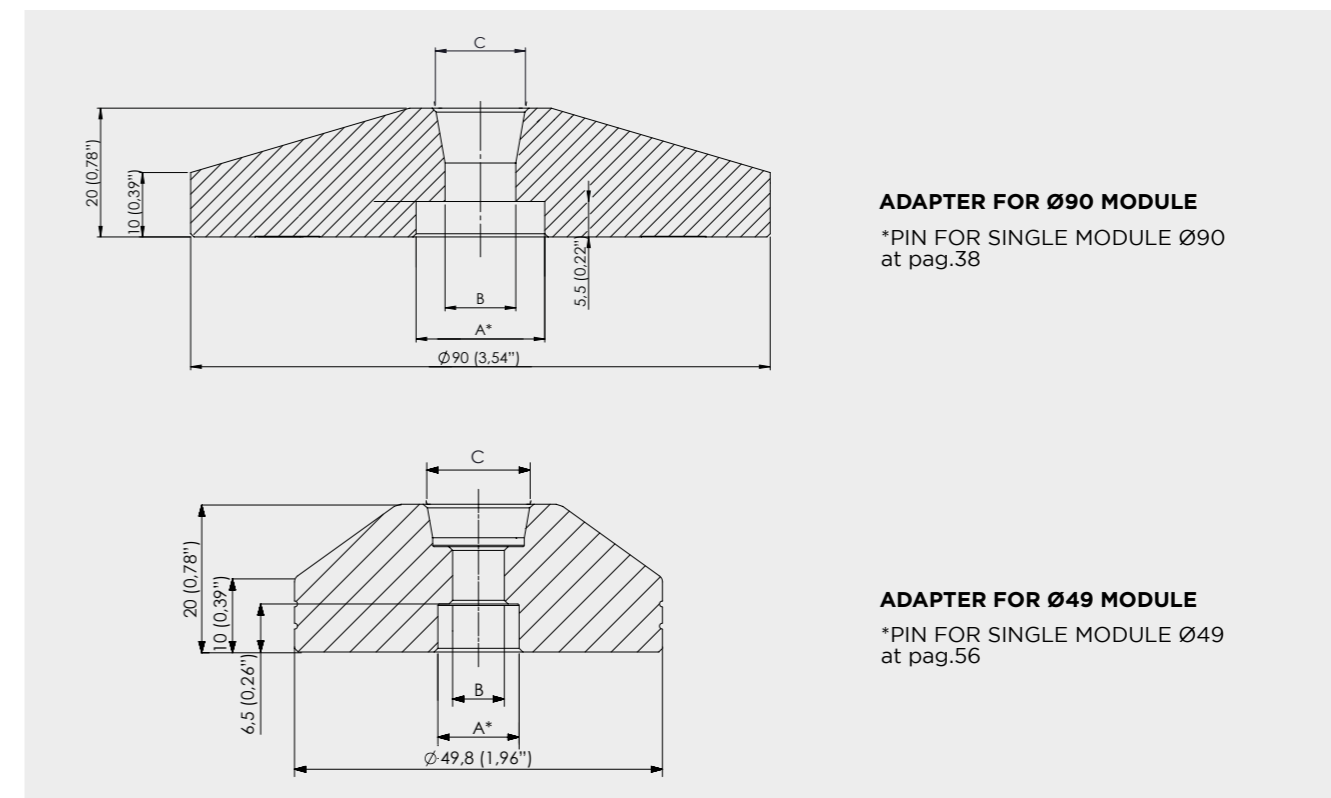

ADAPTER FOR Ø90 MODULE
*PIN FOR SINGLE MODULE Ø90 at pag.38

ADAPTER FOR Ø49 MODULE
*PIN FOR SINGLE MODULE Ø49 at pag.56

PLATES AND BUSHES
MODULES AND PINS D90
MODULES AND PINS D49
SPACERS
RISERS
THIRD POINT
MAGNETIC
VERTICAL CLAMPING
MINI RANGE
FASTMILL ZERO
CLAMPS

PLATES AND BUSHES
MODULES AND PINS D90
MODULES AND PINS D49
SPACERS
RISERS
THIRD POINT
MAGNETIC
VERTICAL CLAMPING
MINI RANGE
FASTMILL ZERO
CLAMPS

ADAPTER FOR MODULE ASSEMBLY EXAMPLE

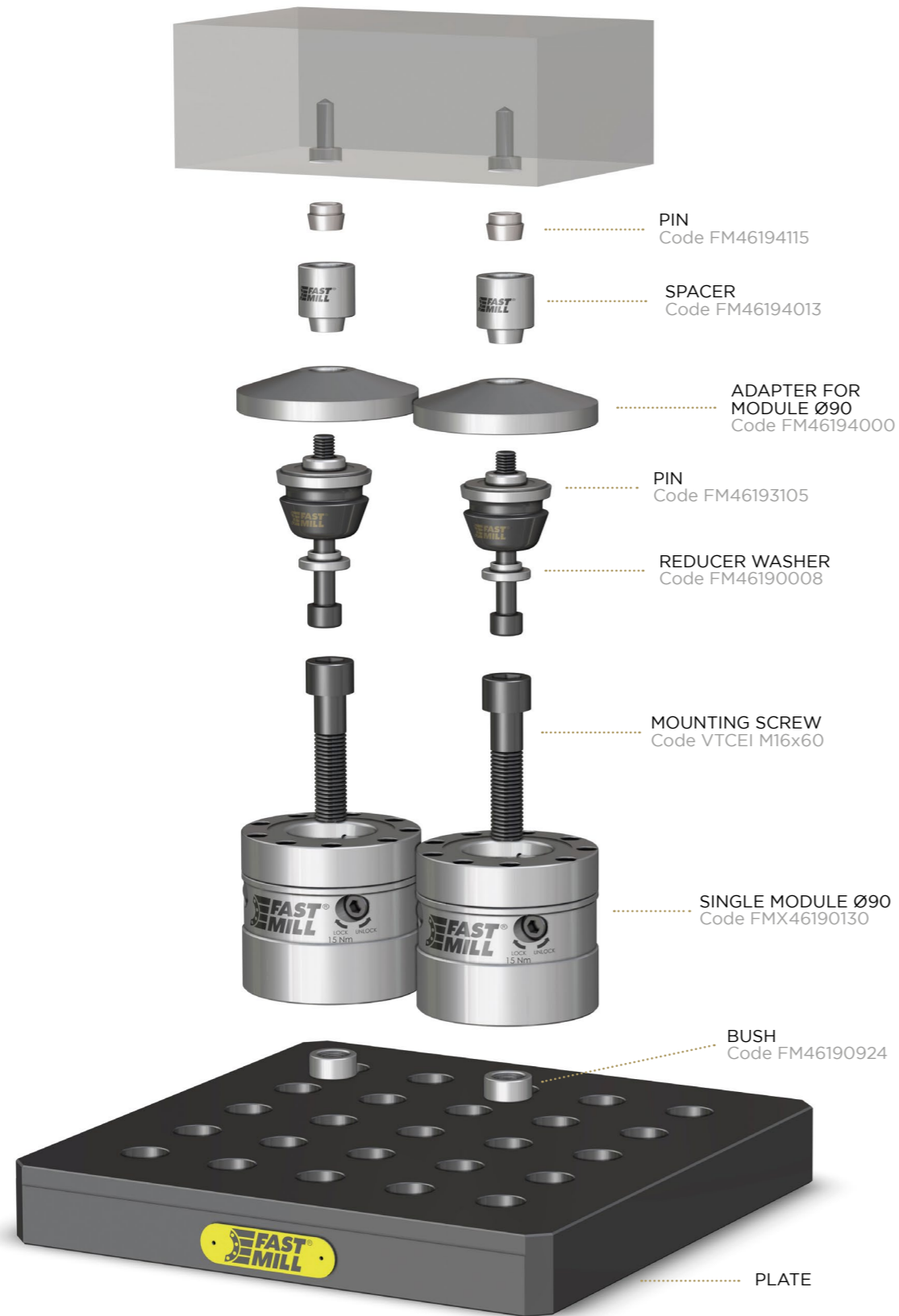

SET UP EXAMPLE

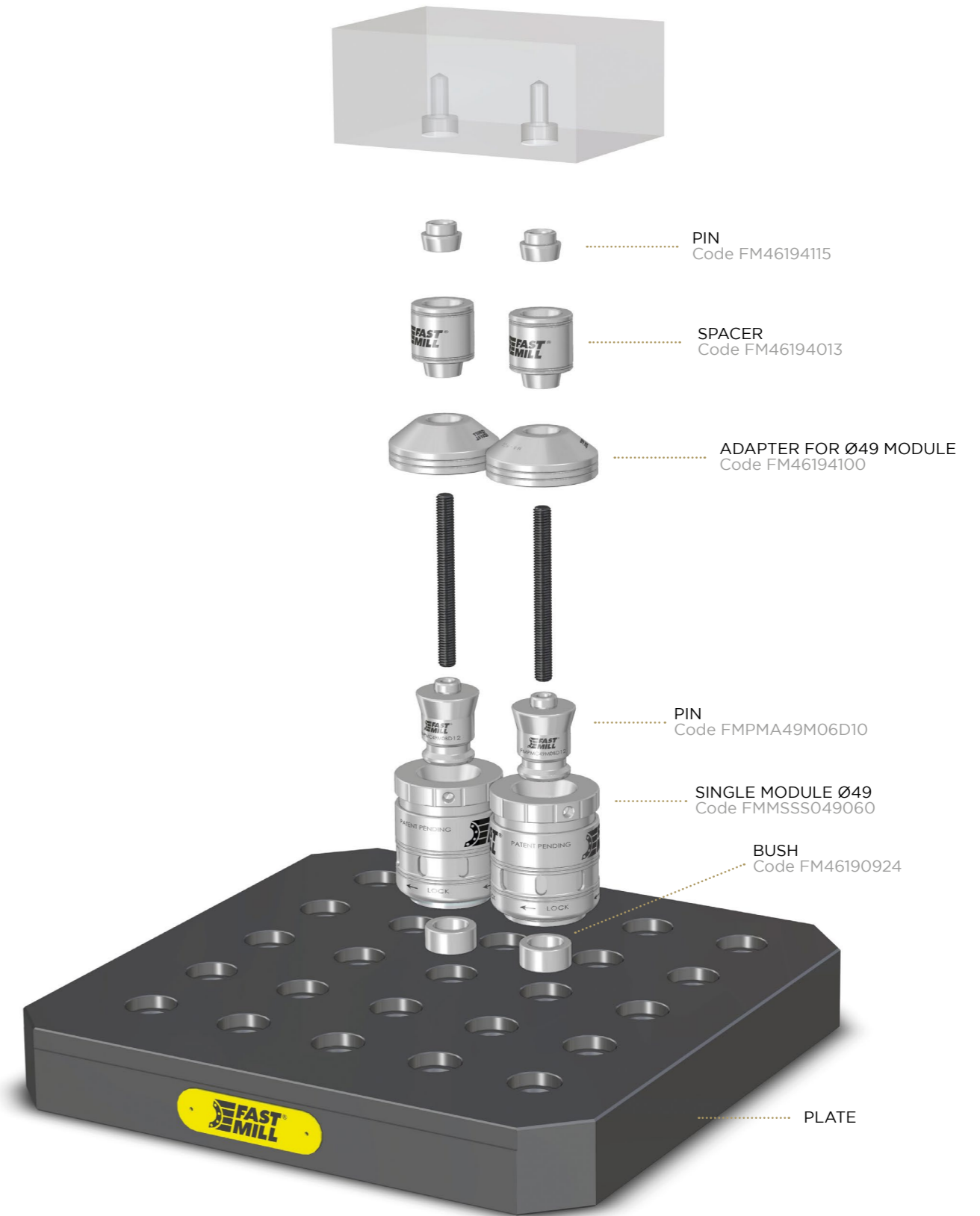

PLATES AND BUSHES
MODULES AND PINS D90
MODULES AND PINS D49
SPACERS
RISERS
THIRD POINT
MAGNETIC
VERTICAL CLAMPING
MINI RANGE
FASTMILL ZERO
CLAMPS

PLATES AND BUSHES
MODULES AND PINS D90
MODULES AND PINS D49
SPACERS
RISERS
THIRD POINT
MAGNETIC
VERTICAL CLAMPING
MINI RANGE
FASTMILL ZERO
CLAMPS